



LIPO70



USER'S MANUAL

Ecomobility Green World S.L.

C/ Horizonte 8, Local 6,
P.I.S.A. 41927 – Mairena del
Aljarafe
Sevilla, Andalucía, España, Europa, The
World

WELCOME TO THE ELECTRIC REVOLUTION

Dear *LIPO70* owner:

Congratulations, you are taking part of the *electric revolution* and from *Ecomobility Green World* we welcome you. The Twenty-First Century will be remembered as the biggest electrification process of urban mobility and this is only possible because of people like you, convinced of changing to a clean and sustainable riding.

The purpose of this manual is to help you understand your electric motorcycle and make the maintenance easier. We hardly recommend you to read that instructions to take the most of your motorbike in a safety way.

Hope you enjoy it!





CONTENTS TABLE

Introduction	04
Safety driving	05
Scooter identification	07
First start	08
Display	09
Controls	10
Acceleration and	12
braking Efficiently	13
driving Battery indicator	14
Battery recharge	16
Technical specifications	18

INTRODUCTION



Your **LIPO70** is a electric scooter that will turn your daily life easier.
You can drive it with your car license and you will never worry again about traffic jams, gas stations or parking.

We call it #instanttorque and we think it is addictive!

DRIVING SAFELY

General instructions before riding:

1) Tire pressures: Check the tires for correct inflation and for any signs of physical damage.

2) Brake check: Squeeze the brake lever (front and rear) as hard as you can, push the scooter forward and check the braking resistance.



This symbol informs you that exposure to high voltage can cause shock, burns and even death.

The high voltage components on the motorcycle should be serviced only by technicians with special training.

3) Battery Check: Make sure your scooter is sufficiently charged for your ride and always check the battery indicator while you are riding. Be sure that battery does not get too low too often. Sometimes the voltage meter on left side of dashboard would be more accurate than bars battery indicator, this is normal because of lithium battery properties. Always charge the battery before using and after every use. More frequently charging is better for battery life.

4) Ready to ride: Make sure the side stand is removed and the killswitch is in “GO” position before riding. If some of that sensors are not ready the scooter will not respond to the accelerator.

5) Steering: Check the handlebar for any damage. Squeeze the front brake and push the handlebar up and down to check for any unusual noise. Move the handlebar in all directions to check for any loose parts or obstructions. Any problems should be corrected before use.

6) Suspension: Check the correct working of the fork and the rear suspension before riding.

DRIVING SAFELY

7) Safety notice:

1.Key in “OFF”: To avoid the scooter moving away unexpectedly, always turn the key to the “OFF” position before dismounting or leaving the scooter unattended.

2.Rear brake: Always engage the rear brake when mounting or dismounting the scooter. Ensure that you are seated on the scooter and check that the stands are clear of the ground before touching the throttle. If you twist the throttle before you are ready to go or while you are mounting the scooter it may move away from you and could lead to an accident.

8) Water and cleaning: Your scooter can be ridden in wet and rainy conditions. When riding in rain, do not ride through deep puddles or muddy areas as excessive water will cause the motor and other electrical components to suffer damage. During cleaning, as with any motor vehicle, be sure to avoid soaking any electrical component to avoid serious damage. Never use high pressure washer when cleaning the bike.

9)Parking: Your bike should not be left in strong, direct sunlight or heavy rain for extended periods of time as it will prematurely age and damage paintwork and the general finish of the scooters appearance and some of the electric components may overheat.

10)Riding: Never ride your bike overloaded. Prolonged use with excessive weight could cause serious damage to the electronic and mechanical parts and void your warranty. It is recommended that all new scooter riders enroll in motorbike riding training.

11)Road rules: As with any vehicle, a scooter rider must always comply with the local road traffic rules and regulations. Before taking your scooter out on a public road, make sure you are familiar with traffic rules and regulations and any special requirements for motorcycles & scooters.

12)Never drink and ride: Alcohol slows reflexes and greatly limits your ability to operate a scooter. Even a very small amount of alcohol will reduce your ability to operate a scooter safely.

SCOOTER IDENTIFICATION



Frame VIN
(steering column)



Identification Plate
(side)

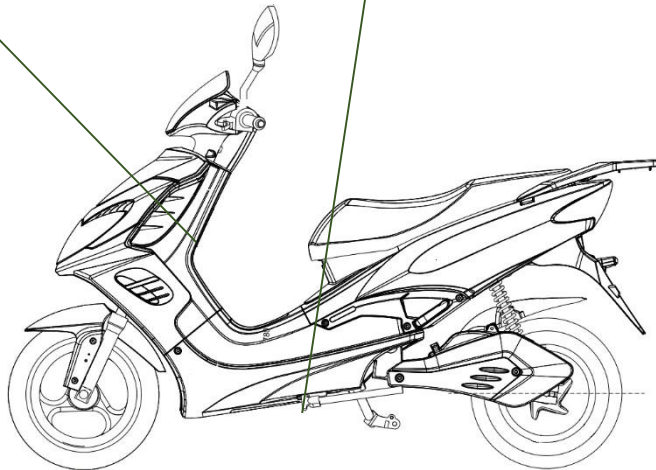

Dealer information:

Name of the Dealer:

Address of the Showroom:

Tlf: _____

E-mail:

Invoice date: _____

Scooter information:

Model:

LIPO70

VIN:

KEY LOCK

The motorcycle has 2 key locks:



Ignition and seat key lock



Seat key lock

Recommendation: The abundant use of keys and key chains in the seat key lock could lead to a premature deterioration of it, due to the weight and jumps during the driving.

KEY LOCK	
OFF	Scooter is turned OFF. The key can be extracted in that position.
ON	Turn the key right. Scooter is turned ON. The key can not be extracted in that position.
LOCK	Press and turn the key left. Scooter is turned OFF and handlebar is locked. To avoid theft, turn the handlebar to the left and turn the key to the LOCK position.

DISPLAY

The display disposes the basic parameters for riding:

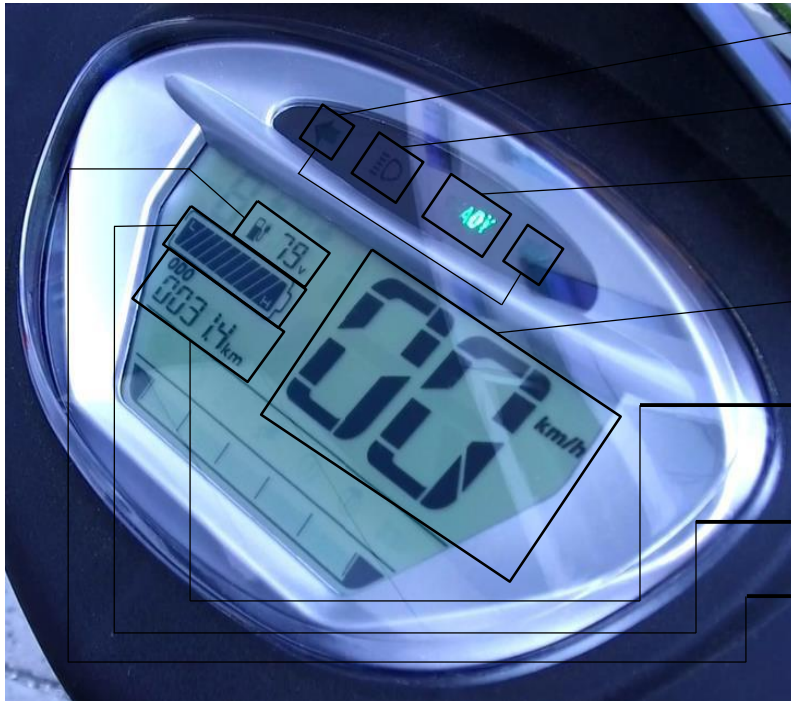

1. **Turning lights:** Right and left turning lights indicator LEDs
2. **High beam:** High beam indicator LED
3. **READY:** Indicates that the HV system is connected while 0km/h (ready to ride).
4. **Speed:** Indicates speed digitally measured in km/h (EU homologation).
5. **Odometer (ODO):** measure the amount of km made by the bike since the manufacturing.
6. **Battery level:** Battery estimated remaining capacity.
7. **Vo (V):** Measures battery voltage.

Remember: In running order, Voltage indicates remaining battery better than Battery Level. See [Battery Indicator chapter](#) to reach a deep understanding about it.



CONTROLS

CONTROL	ACTION
High beam	Fixed light: Push the switch up
	Burst light: Push the button down
Turning signal switch	Right lights: Slide right Turn blinkers OFF: Push central button Left lights: Slide left
Claxon button	Sound the claxon: Push
Rear brake lever	The accelerator will be interrupted while any brake lever is pushed. The acceleration will start again when you release the brake lever and turns the throttle. <i>Rear mechanical brake + Rear regenerative brake.</i>



CONTROLS



CONTROL	ACTION
Throttle grip	Torque : Twisting the throttle grip
Reverse	Riding backwards: Press the Reverse button and twist the throttle to ride backwards.
Killswitch	Disables traction: Interruptor "OFF" 
	Enables traction: Interruptor "ON" 
Front brake lever	<p>The accelerator will be interrupted while any brake lever is pushed. The acceleration will start again when you release the brake lever and turns the throttle.</p> <p><i>Front mechanical brake + Rear regenerative brake.</i></p>

ACCELERATION AND BRAKING

Acceleration tips:

1. Turn the key "ON" and check the killswitch is in "ON" position. Remove the side stand and then your bike will be ready to ride as soon as you twist the throttle.
2. Your scooter has a great acceleration capability. To avoid losing control you must twist the throttle slowly while speed increases gradually.
3. Don't twist the throttle until you are ready to ride.
4. After braking, make sure you release the throttle, release the brake levers, and then twist the throttle again.
5. The electric brushless motor emits a magnetic slight noise when accelerating. It's the silent revolution that's coming.
6. For your safety, turn the key in "OFF" position while you are not riding.

Deceleration tips:

1. To stop the bike, release the throttle and push the front and rear brakes simultaneously. Both brakes activates the reg. braking in addition to the mechanical disc brake.
2. For your safety, the scooter has a button on the brake lever. When you push front or rear brakes the motor controller disables the traction. Release the throttle during braking, and twist it smoothly after releasing the brake lever to accelerate again.

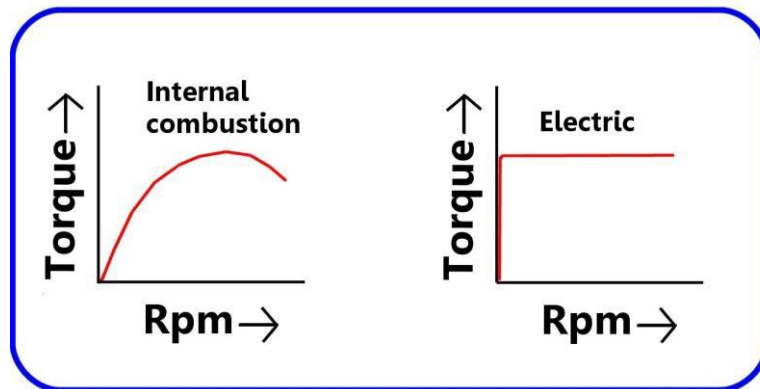

TORQUE = Acceleration
capability (measured in Nm)

RPM = Revolutions per minute

¡Electric motors give instant torque from 0 rpm!

#instanttorque

EFFICIENTLY DRIVING

Tips for increasing efficiency (maximum range) :

1. Accelerate gradually and smoothly. Avoid quick unnecessary accelerations.
2. Avoid hard braking, try to anticipate to the brake necessity with time enough to stop the scooter by reg. braking when possible.
3. Release the throttle and ride free of energy consumption when possible.



Factors that affects the efficiency

CONTROLLABLE	MAINTENANCE		DRIVING	
Maximize Autonomy	Filled tires	Strong bodywork	Calm driving	Reduced load
Reduce Autonomy	Deflated tires	Loose bodywork	Aggressive driving	Overload

EXTERNAL	ROUTE				WEATHER	
Maximize Autonomy	Slow speed	Plain road	Solid road surface	Minimum stops	Warm	Windless
Reduce Autonomy	High speed	Uphill and downhill	Bumps and sand surface	Several stops and starts	Very cold or very hot	Strong winds

BATTERY INDICATOR

10 bars display



BARS INDICATOR	VOLTAGE	DESCRIPTION
10/10	More than 80V	Full battery
7/10	Less than 78V	Half battery
Less than 3/10	Less than 72V	Low battery

LOW BATTERY:

Under 72V the controller will limit the output current to the motor, therefore the top speed will be reduced to save energy. If that happens, make sure the scooter has enough battery to reach an available plug.

Some times voltage meter is more accurate than bars indicator.

Accelerating and reg. braking rises and lowers voltage.

Battery estimated state of charge (SoC) is more accurate after a few minutes with bike keyed OFF.

BATTERY INDICATOR

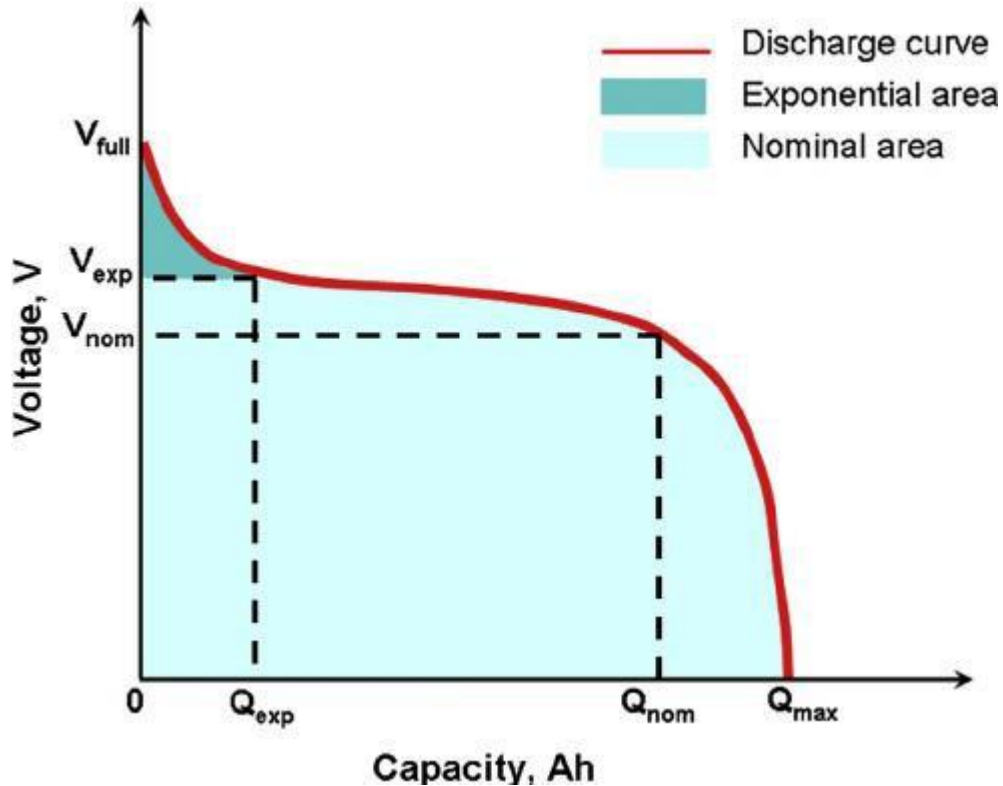

That's an example about how your battery gets discharged:

1st stage: Exponential area. From 84V to 78V
You will notice that first run after charging will easily burn the first battery indicator bar.
Don't worry, it won't be proportional!

2nd stage: Nominal area. From 78V to 65V
Most of the time you will run in nominal area.

The scooter will stop working at about 65V as full discharge for safety reasons and battery longevity.

BATTERY RECHARGE

● The battery must be charged through original external charger (AC-DC converter) for maximum longevity and to preserve warranty.

NEVER PLUG THE BATTERY DIRECTLY TO THE GRID (AC).

● Turn the circuit breaker disconnected while charging the battery connected to the controller.

● The charger connects to a conventional Schuko plug.

● Estimated charge time is 5h from 0 to 80%. Over 80% charge gets slower for battery longevity. Full charge may take about 8h.

● To maintain battery in optimum conservation, it is not recommended to discharge them under 30% if not necessary. We strongly recommend charging the battery before every use.

● The battery chemistry is NMC configured as 72V25Ah nominal (1.8kWh). 84V max.

● NMC batteries has no memory effect, therefore you don't need to full discharge it to achieve a good performance.

● The battery can be charged no matter the state of charge (SoC). Charging it frequently will increase battery lifespan.

● The temperature range for charging your battery is 0°C to +35°. Do not charge the battery under 0°C or over 35°C. Riding range is -15°C to +40°C.

Remember to keep the battery about 60% (76V) and cut off the circuit breaker when long periods of inactivity, and keep checking battery voltage every month if possible.

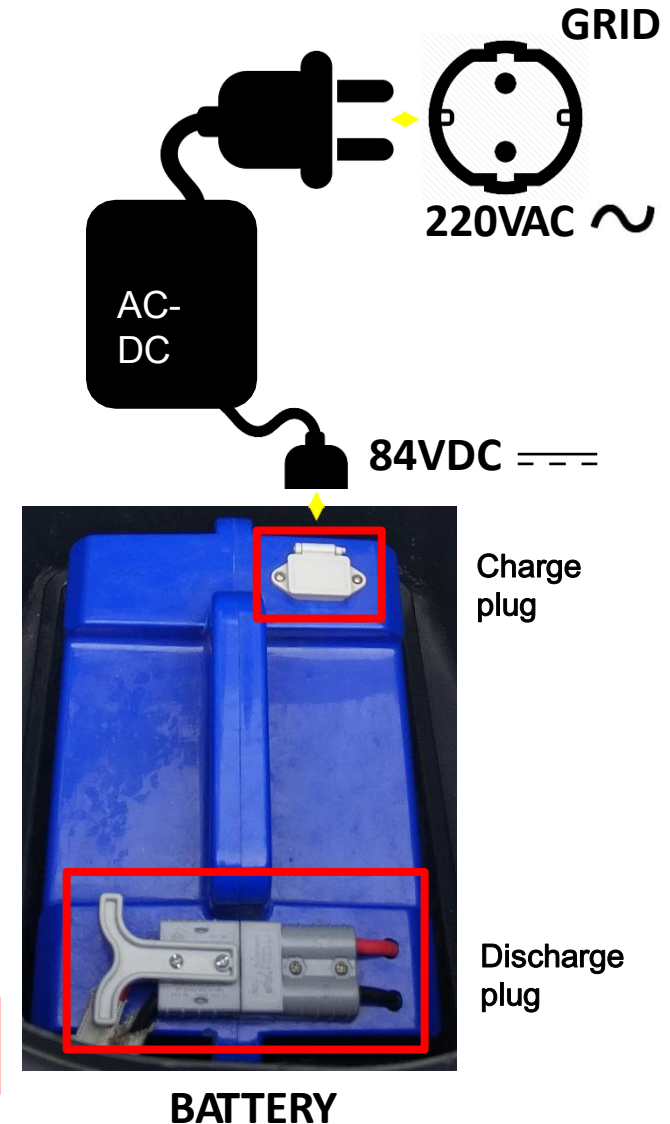

LONG PERIOD OF DISCONNECTION

In case of a long period of disconnection, that means that the battery has been removed during exceeded time, the vehicle's controller gets in standby mode that prevent an usual ignition.

To deactivate this state, the user must follow the following steps:

1. If we can use the proprietary charger, connect it to the battery while the battery is connected to the motorbike and turn on the vehicle.
2. If we do not have the charger:
 1. Disconnect the discharge plug while the vehicle is off.
 2. Connect again the discharge plug.
 3. Turn on the motorbike.
 4. Repeat the process until it works.



Charger connected



Discharge plug connected



Discharge plug disconnected

MAINTENANCE GUIDE

The nucleus of the motorcycle is a electric propulsion system which doesn' t need any maintenance. Thanks to its 12" hub engine technology and to its air refrigeration system for the battery, engine, controller and charger, we can forget all the usual noises, vibrations and maintenance typical of combustion motorcycles.

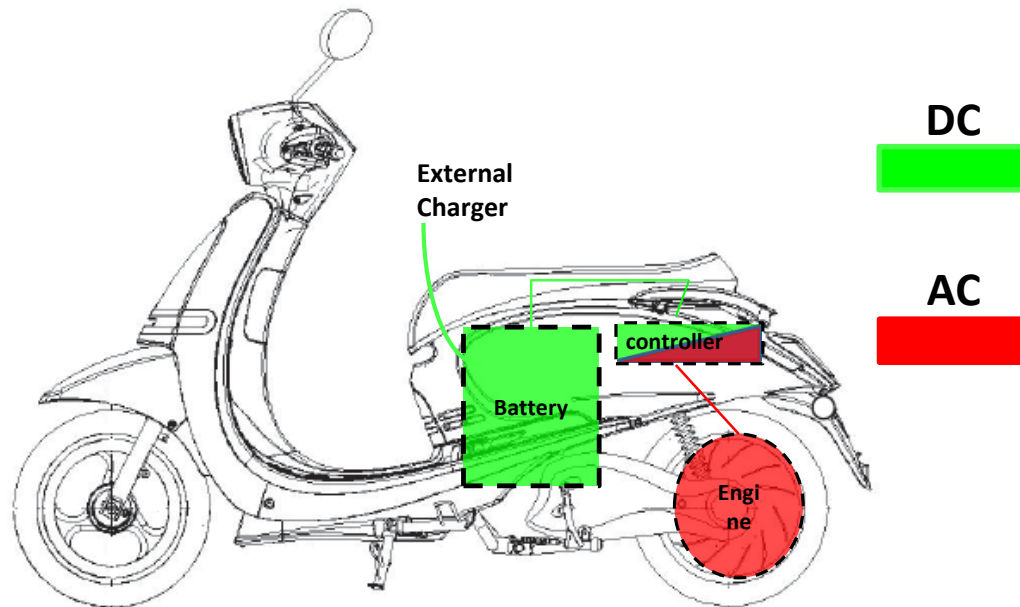

FOR THE FIRST USERS OF AN ELECTRIC MOTORCYCLE:

Due to the absence of noises and vibrations of the engine, while driving en electric motorcycle, you will perceive the noises and vibrations of the mechanical components, like tyre friction, headset chafing, disc and spark plug friction, etc.. And you' ll perceive as well the noises of road, This is normal and it doesn' t affect the correct functioning of the vehicle.

	Motor Oil
	Oil filter
	Spark plug
	Carburation

	Speed variator
	Drive belt
	Air filter
	Valve adjustment
	Coolant

MAINTENANCE GUIDE

The maintenance of our scooter is simple and basic:

Brakes:

- ✓ Check the liquid properties
- ✓ Check the pads and disc brake status
- ✓ Check the brake levers

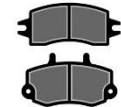

Tyres:

- ✓ Check the tyres pressure and status
- ✓ Check the axis and the bearings status

Steering, fork, rear suspension and swingarm:

- ✓ Check the play and tightenings
- ✓ Check if there are leaks in the roadblocks
- ✓ Check suspensions junction to the chassis



Other mechanisms to check preventively :

- ✓ Passenger footrest
- ✓ Ignition and seat key lock
- ✓ Locking system of the seat
- ✓ Side easel
- ✓ Central easel

NECESSARY MAINTENANCE

FIRST CHECK	1.000km / 6 months
RECURRENT MAINTENANCE	6.000 km / 1 year

Brakes liquid

DOT 3 o DOT 4

Tyre pressure:

Medium cargo:

200 kPa front

230 kPa rear

Maximum cargo:

230 kPa front





250 kPa rear

In summary: Scooters must be checked at least every 6.000km or 1 year to perform a preventive maintenance of all common scooter components to keep it in optimal condition. That maintenance can be done in your trusted repair shop.

The maintenance can be carried out by your trusted mechanic. He just has to contact us in order to add him to our partners' network.

Contact us:

service@ecomobilitygreenworld.com

	Brake fluid	6.000km / 1year → Check (Replace at least every 2 years)
	Brake pads	6.000km / 1years → Check (Replace if necessary)
	Tires pressure and condition	6.000km / 1years → Check (Replace if necessary)
	General lubrication	6.000km / 1year → Lubricate (Grease or oil depending on component)
	Bolts tight	6.000km / 1year → Check (Adjust if necessary)

NECESSARY MAINTENANCE

Headlight height:

The regulation bolt of the front headlight is situated behind the upper front cover of the scooter, in the upper part of the light bulb.

COMPONENT	REFERENCE
Headlight	3x 12V 3W3
High/low beams	1x 35/35W 12V
Front turnal lights	2x R10W 12V
Rear turnal lights	2x R10W 12V
Rear and brake light	1 X 12V 21 5W
Number plate light	1x 12V 5W
Display	LED

Access to the regulator



Regulator



TECHNICAL SPECIFICATIONS

MOTOR	
Motor type	BLDC 12-3000
Motor location	Rear Wheel hub motor
Motor controller	110A FOC controller
Torque (max/nominal)	120 Nm
Power (max/continuous)	5,6kW / 5kW
Reverse mode	YES

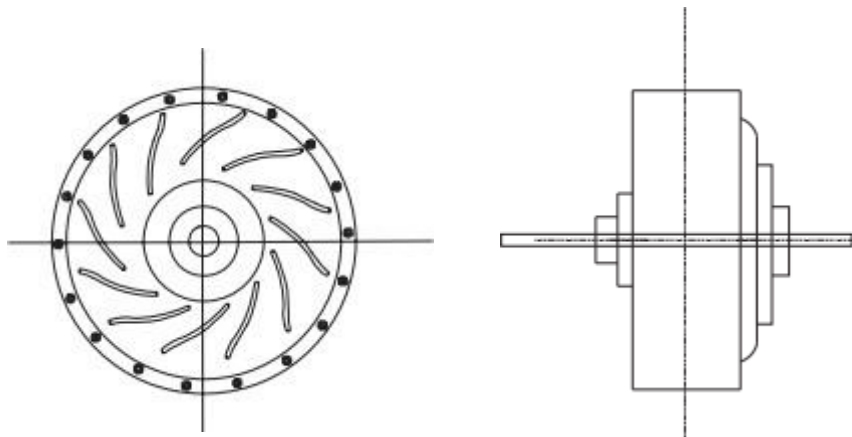

BATTERY	
Battery type	Li-ion NMC
Nominal voltaje	72V
Max voltaje	84V
Nominal Capacity	40Ah
Max / Nominal Energy	3,36kWh / 2,88 kWh
Charger type	CC – CV Li-ion battery charger
Charger max power	300 W (84V – 5A)
Charging time 0-80%	7h
Charging time 0-100%	10h (depending on load balancing)
Battery lifespan	1200 ciclos hasta 80% de capacidad @ 100% DoD

TECHNICAL SPECIFICATIONS

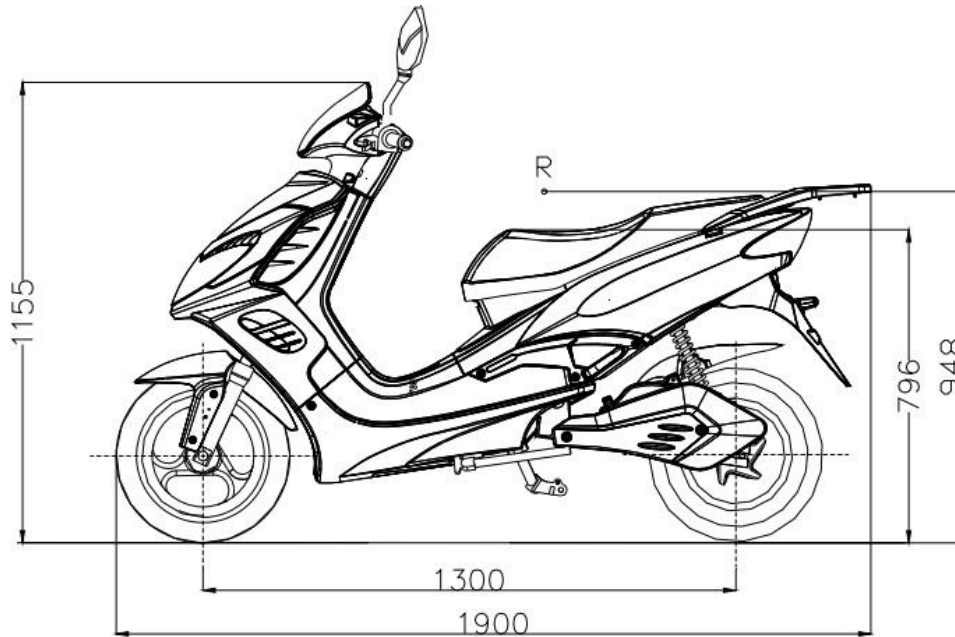

WEIGHT AND CARRYING CAPACITY	
Weight without battery	99 kg
Battery weight	16 kg
Total weight	116 kg
MMA	266 kg
Carrying capacity	150 kg

CYCLE PARTS / BRAKES	
Front Wheel	Aluminum Wheel 12" (90/90-12)
Rear Wheel	Hub motor 12" (90/90-12)
Rear Wheel	Telescopic Fork
Front suspension	Double Shock Absorbing
Rear suspension	220mm
Front brake	220mm
Rear brake	1900mm
Total length	680mm
Seat height	810 mm
Wheelbase	1330mm
Total height (no-mirrors)	1130mm

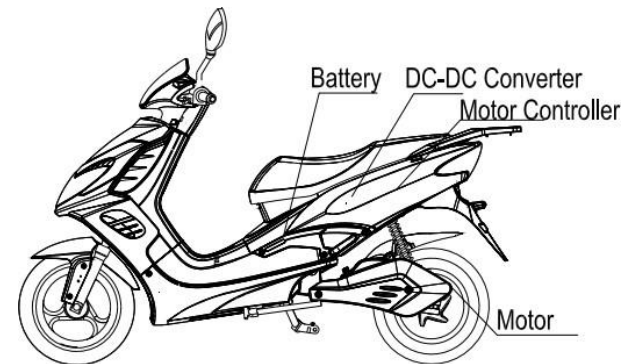

Vocabulary	
VIN	Vehicle Identification Number
CBS	Combined Brake System
MMA	Maximum Mass Authorised
UE	European Union
PMSM	Permanent Magnets Synchronous Motor
Li-ion	Lithium ion
NMC	Nickel, Manganese, Cobalt
CC-CV	Direct Current – Direct Voltage
<i>Kill-switch</i>	Master Switch

Vocabulary	
SoC	State of Charge
DoD	Deep of Discharge
SoH	State of Health
V	Voltage (Volts)
A	Current (Amperes)
Ah	Relative Capacity (Amperes hour)
kW	Power (Kilowatts)
kWh	Energy (Kilowatts hour)
Nm	Torque (Newton meter)





Ecomobility Green World
[C/ Horizonte 8, Local 6](#)
41927 Mairena del Aljarafe
Sevilla – Andalucía –
España

info@ecomobilitygreenworld.com
www.ecomobilitygreenworld.com